

High Efficiency Industrial Motors
PERMANENT MAGNET
SYNCHRONOUS **MOTOR**

Voltpro
“ Upgrade your energy “

/ Permanent Magnet Synchronous Motor

VoltPro is a new industrial motor range to meet high efficiency needs of industry by IE5 and higher efficiency class. Main advantage of this product is cost effective solution ensured by using standard ferrite magnet in rotor design.

In motor design, main properties of two different motors are combined in one motor that can run with vector control driver at higher efficiency than IE5 energy efficiency level.

Reluctance and permanent magnet synchronous motor technologies are combined in one motor. Rotor magnetic circuit is designed in the way of that motor can produce both magnet and reluctance torque. Magnets are inserted lamination to get saliency between "d and "q" axis of rotor.

Low copper loss is achieved by using needle winding technology by decreasing end-turn dimensions. As known, needle winding causes high torque ripple. The magnetic circuit design is optimized to decrease torque ripple lower than %15.

Motor has sinusoidal EMF form for field oriented control (FOC) for high efficiency, torque & speed control in all application types, such as pumps, fans, compressors, traction, lifting etc. Most available application type is variable speed application where currently a driver is used. VoltPro PMSM motor can be replaced with current IE2 or IE3 motor.

/ Product Range

RPM	1500											3000											
Power [kW]	0.25	0.37	0.55	0.75	1.1	1.5	2.20	3	4	5.5	7.5	0.37	0.55	0.75	1.1	1.5	2.2	3	4	5.5	7.5	11	15

/ Main Technical Properties

	1500 rpm	3000rpm
Motor Input Rated Voltage [V]	400	400
Rated Frequency [Hz]	125	250
Pole number	10	10
Thermal class	F	F
IP	55	55
Maximum speed [rpm]	3000	6000

	1500 rpm	3000rpm
Duty cycle	S1	S1
IP	55	55
Amb. Temp [°C]	40	40
Cooling	IC411	IC411
Frequency range	5-250	5-500
EMF form	Sinus	Sinus

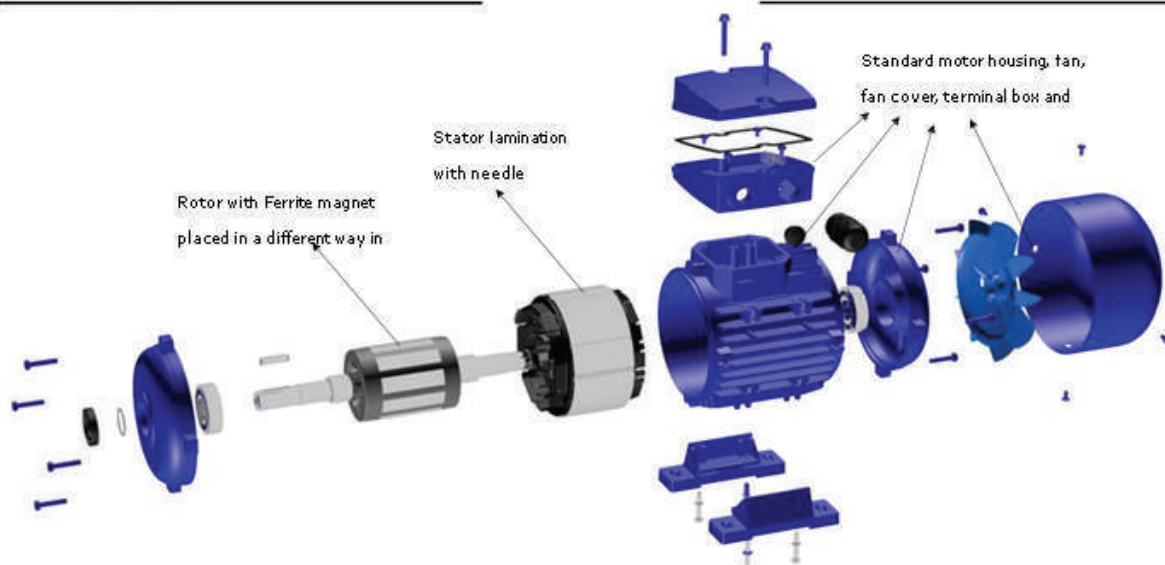

/ Permanent Magnet Synchronous Motor Range

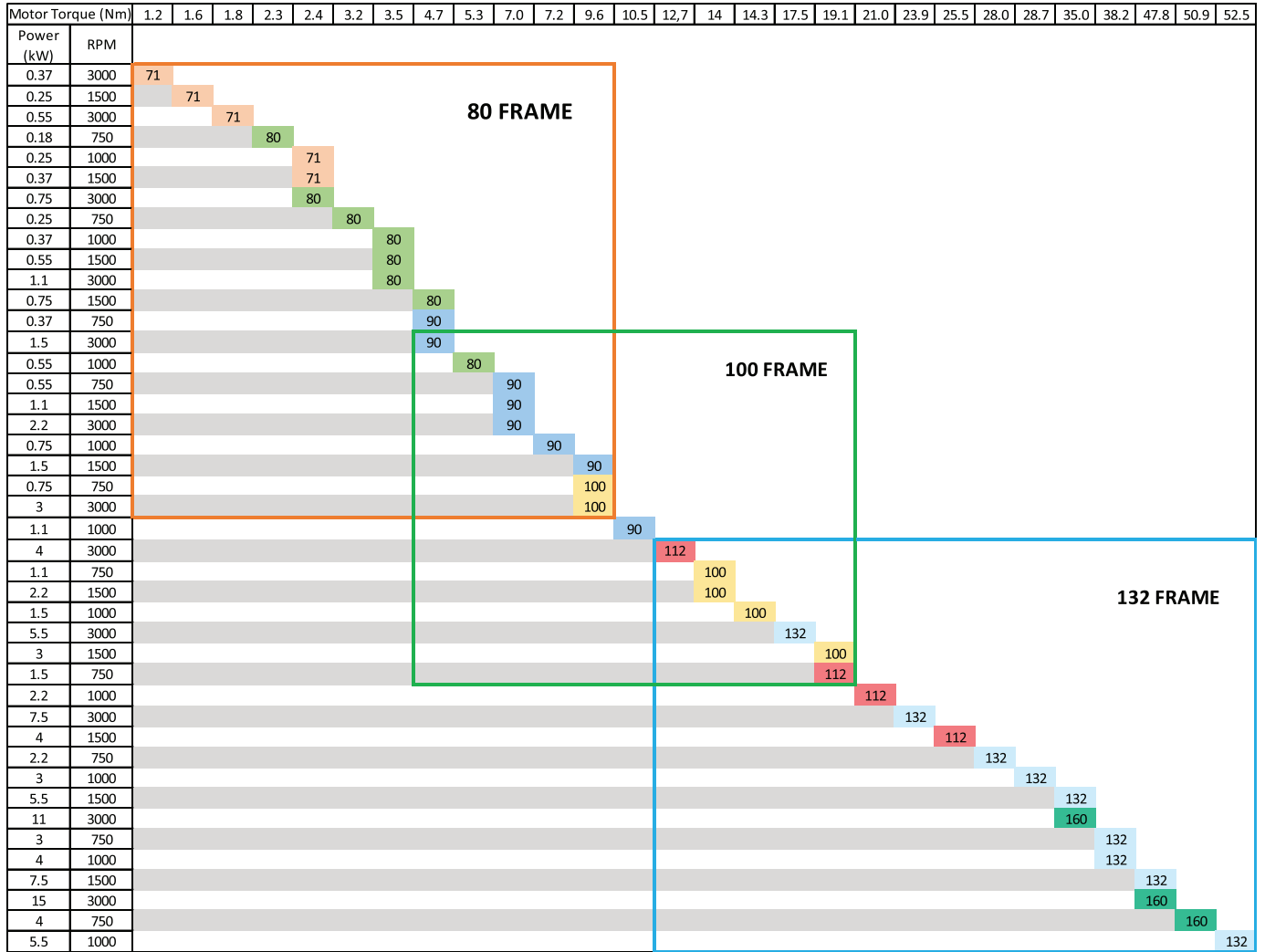

/ Performance Graphs for 80 Frame Motors

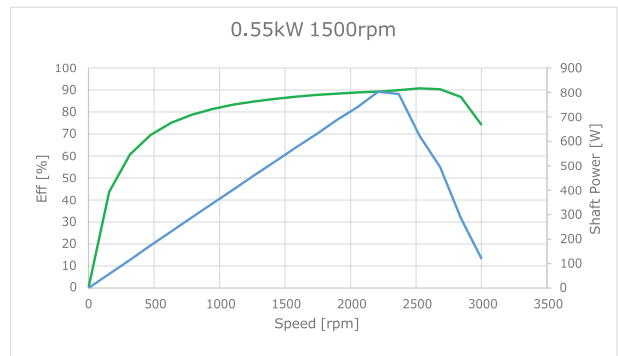
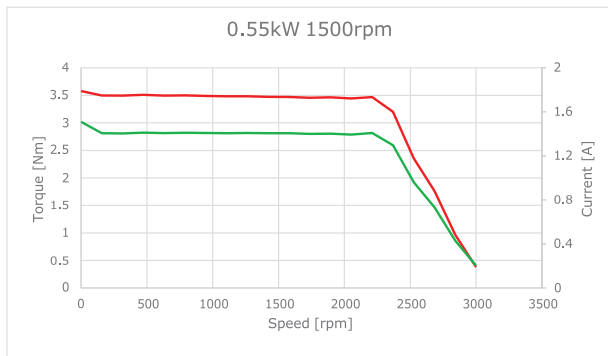

/ Performance Graphs for 80 Frame Motors

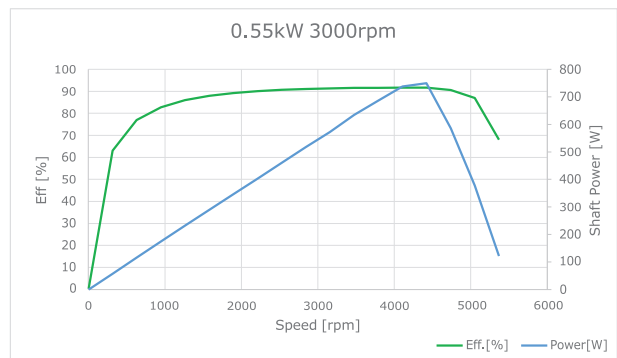
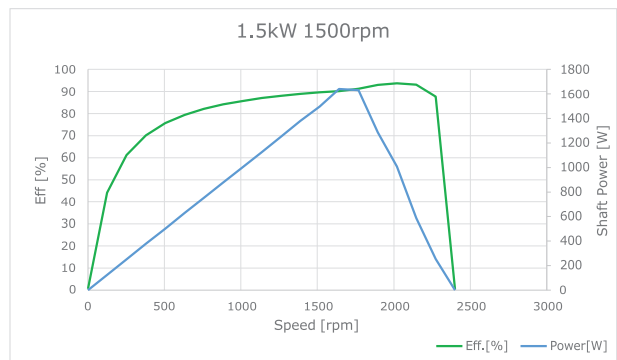
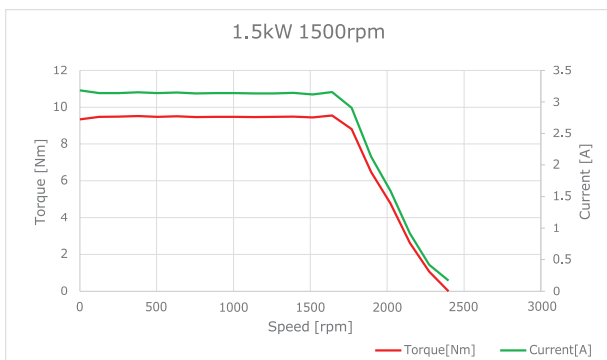
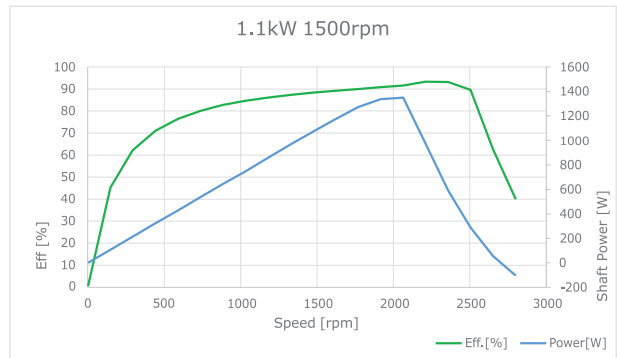
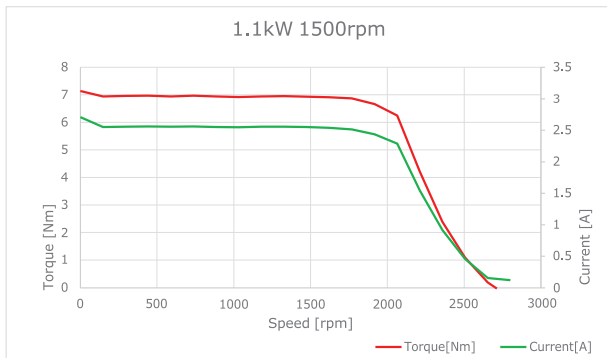
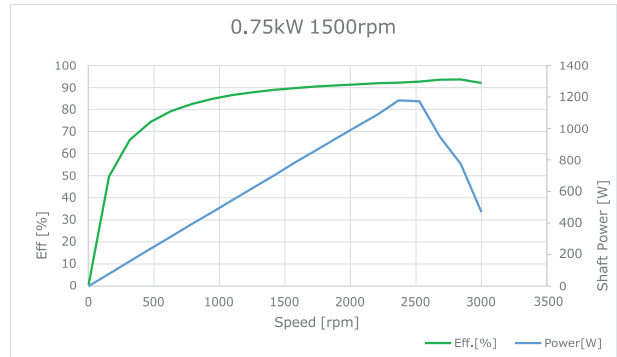
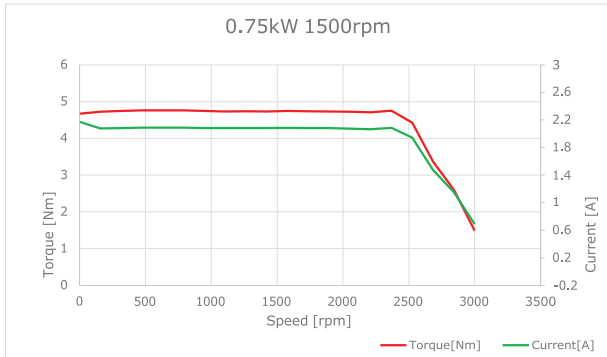

/ Performance Graphs for 80 Frame Motors

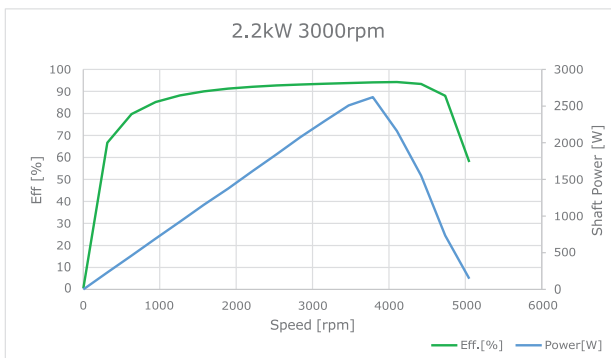
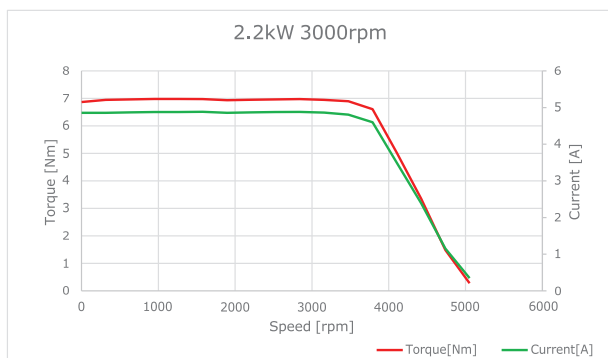
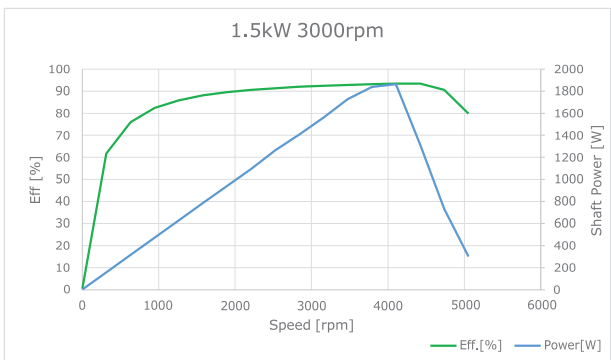
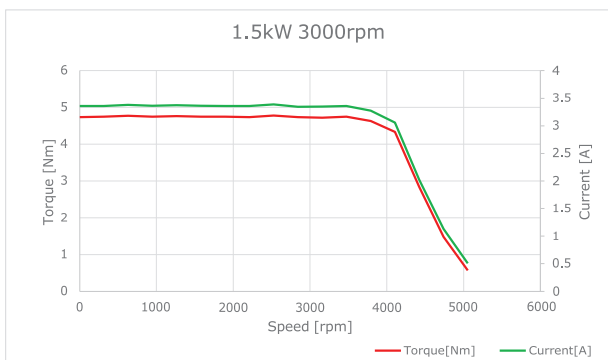
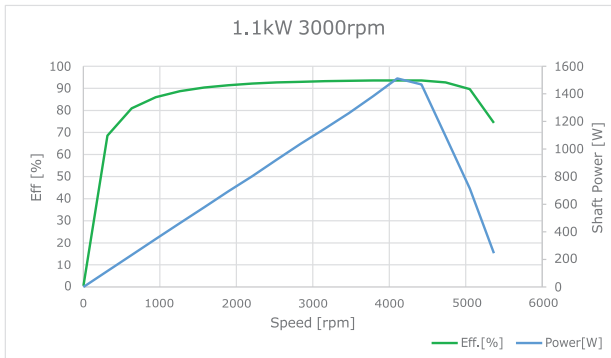
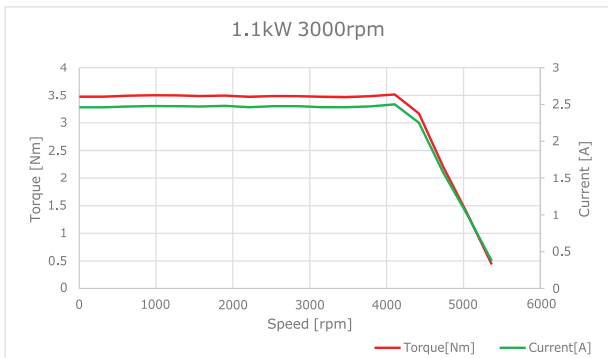
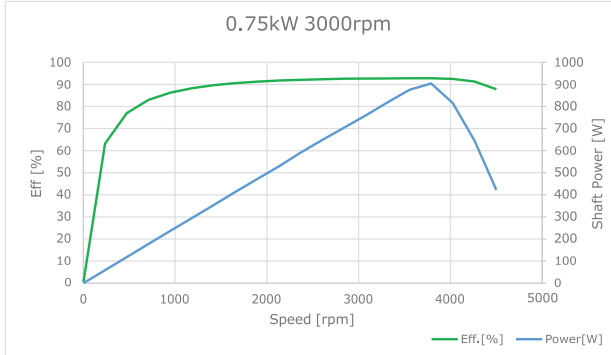
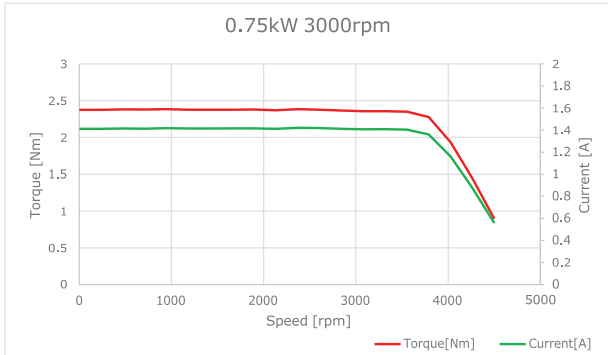

Base speed [rpm]	Frame	kW	Nm	Rated Current [A]	Rated Eff [%]	Max.Torque [Nm]	Max. Current [A]	Max. "d" axis Current [A]	Max. Speed [rpm]
1500	80	0.55	3.5	1.4	86.4	10.5	5.6	7	3000
	80	0.75	4.8	2.1	89.3	14.4	8.4	10.5	3000
	80	1.1	7.0	2.6	88.9	21.00	10.4	13	3000
	80	1.5	9.6	3.2	89.5	28.8	12.8	16	3000
3000	80	0.55	1.8	1.2	91.2	5.4	4.8	6	6000
	80	0.75	2.4	1.4	92.6	7.2	5.6	7	6000
	80	1.1	3.5	2.6	93.5	10.5	10.4	13	6000
	80	1.5	4.8	3.4	92.3	14.4	13.6	17	6000
	80	2.2	6.4	4.9	93.5	19.2	19.6	24.5	6000

/ Performance Graphs for 100 Frame Motors

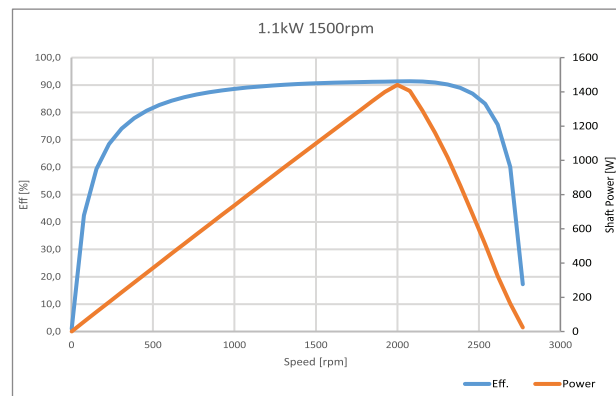
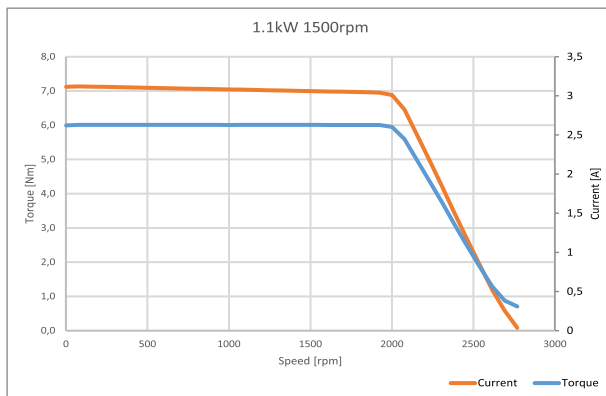
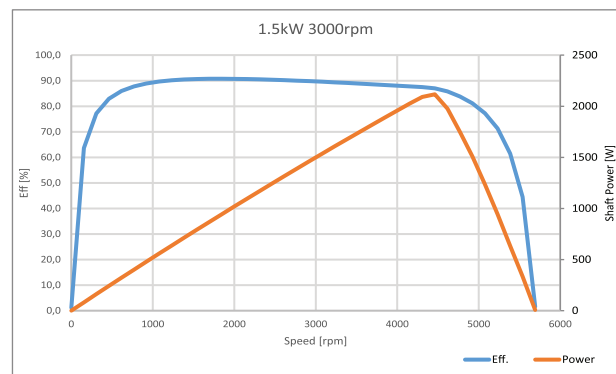
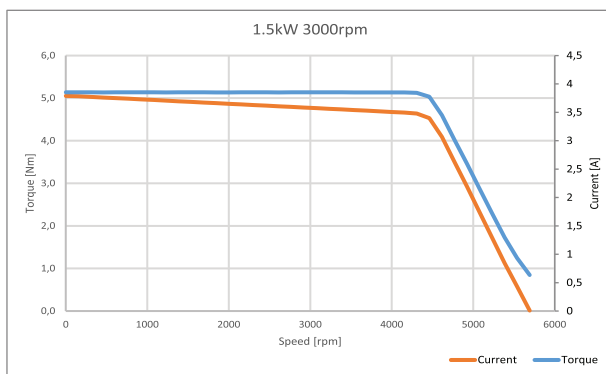
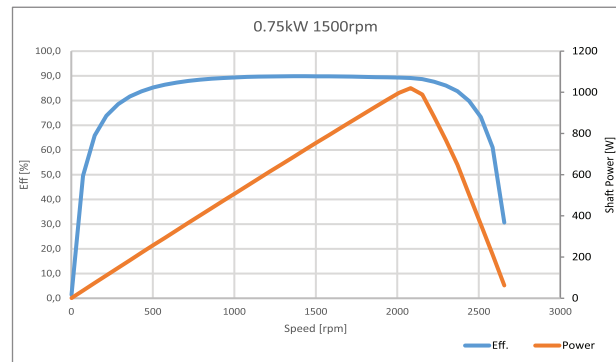
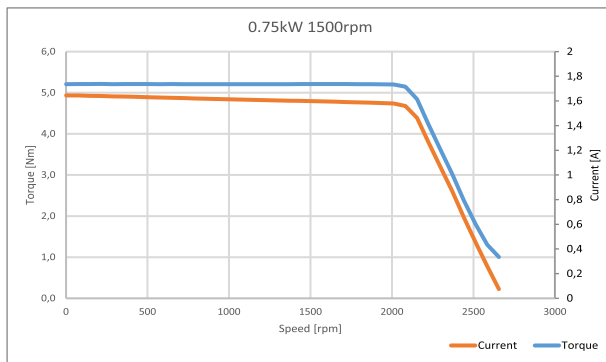

/ Performance Graphs for 100 Frame Motors

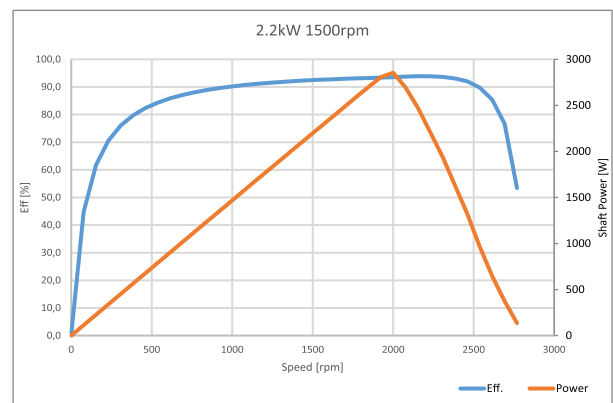
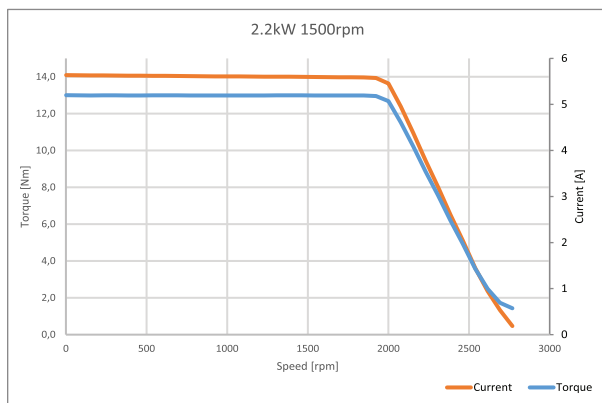
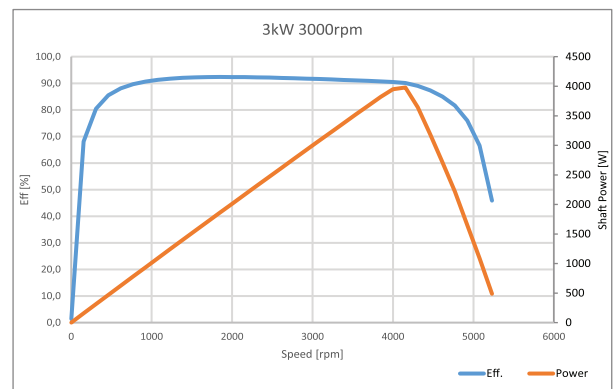
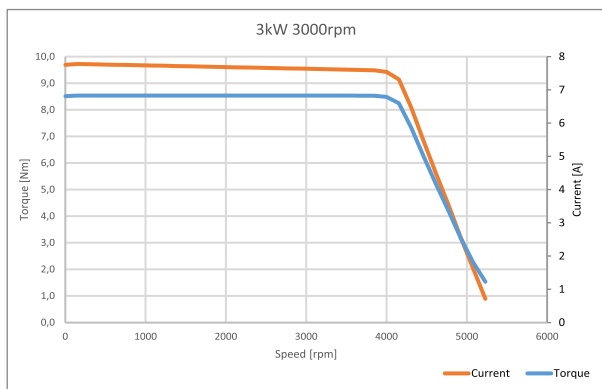
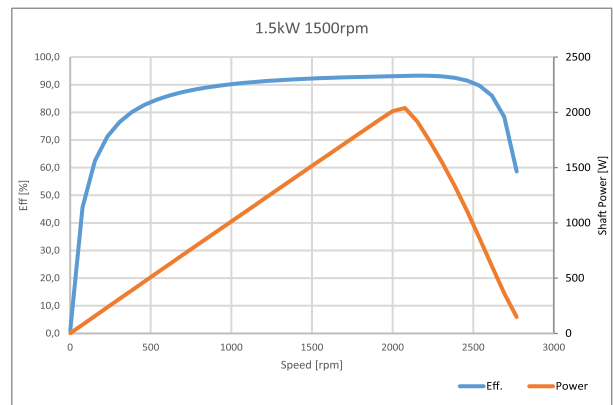
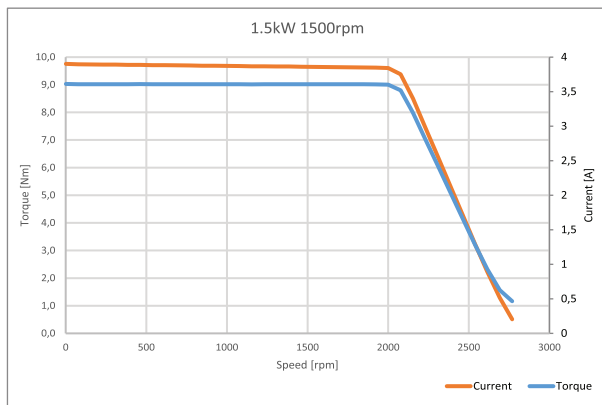
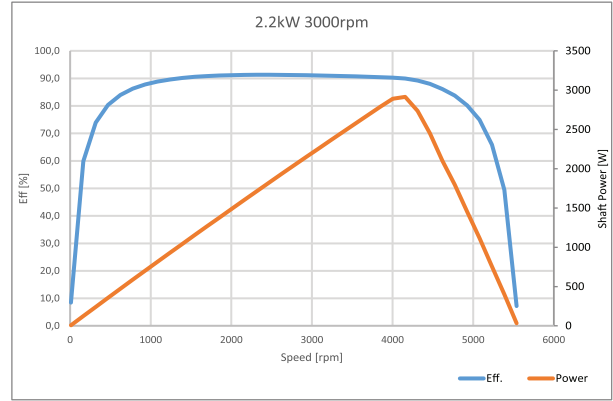
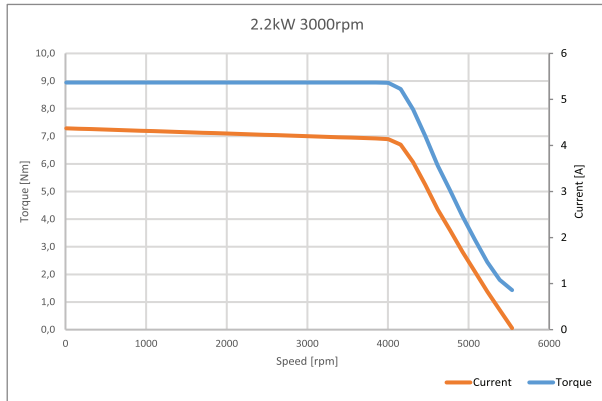

/ Performance Graphs for 100 Frame Motors

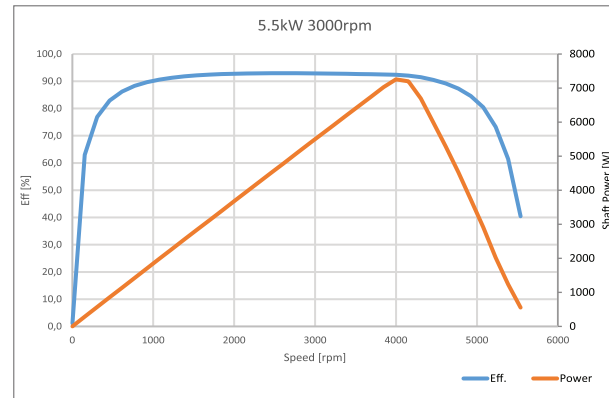
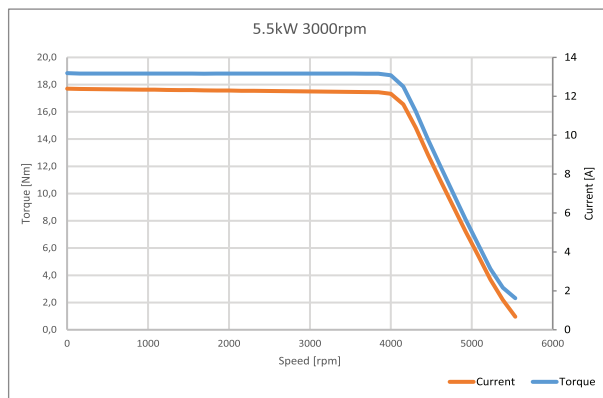
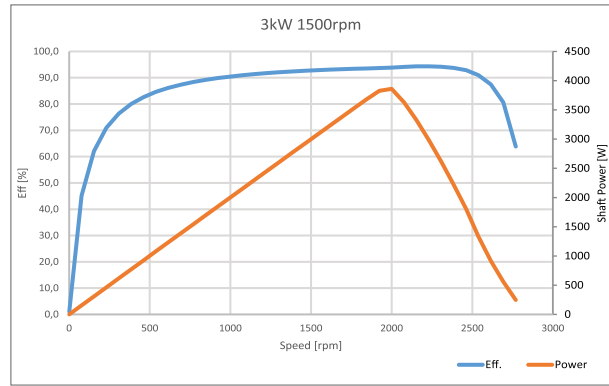
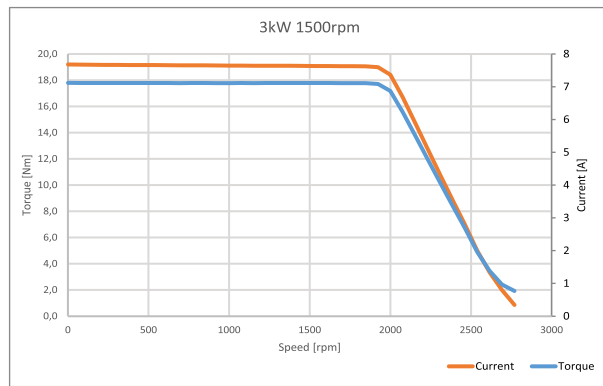
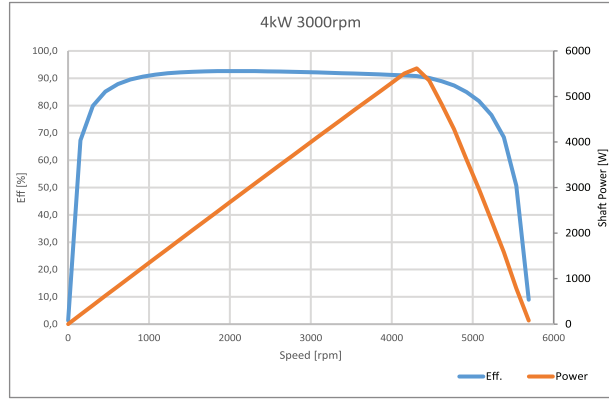
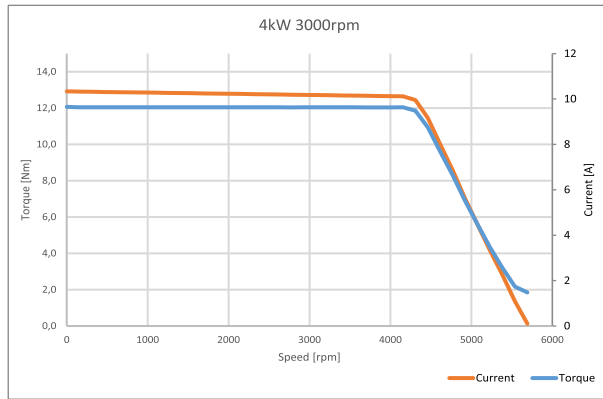

Base speed [rpm]	Frame	kW	Nm	Rated Current [A]	Rated Eff [%]	Max.Torque [Nm]	Max. Current [A]	Max. "d" axis Current [A]	Max.Speed [rpm]
1500	100	0,75	4,8	1,7	89,8	14,4	5,1	8,5	3000
	100	1,1	7	2,7	90,6	21	7,8	13,5	3000
	100	1,5	9,5	3,6	92,2	28,5	10,6	18	3000
	100	2,2	14	5,2	92,4	42	15,6	26	3000
	100	3	19,1	7,2	92,7	57,3	21,3	36	3000
3000	100	1,5	4,8	3,9	89,7	14,4	11,2	19,5	6000
	100	2,2	7	5,4	91,1	21	15,7	27	6000
	100	3	9,5	6,8	91,6	28,5	20,1	34	6000
	100	4	12,7	9,7	92,2	38,1	28,6	48,5	6000
	100	5,5	17,5	13,2	92,8	52,5	40	66	6000

/ Driver Selection Chart

VoltPro electronic is used to drive PMSM motor with sensor or sensorless. Drive type is FOC (Field Oriented Control).

RPM	1500				3000				
Power [kW]	0,55	0,75	1,1	1,5	0,55	0,75	1,1	1,5	2,2
Current [A]	1,40	2,10	2,6	3,2	1,20	1,40	2,6	3,4	4,9
	VoltPro 0.75kW Input: 3~ 400V Output: 3~ 400V 0-500Hz	VoltPro 0.75kW Input: 3~ 400V Output: 3~ 400V 0-500Hz	VoltPro 1.5kW Input: 3~ 400V Output: 3~ 400V 0-500Hz	VoltPro 1.5kW Input: 3~ 400V Output: 3~ 400V 0-500Hz	VoltPro 0.75kW Input: 3~ 400V Output: 3~ 400V 0-500Hz	VoltPro 0.75kW Input: 3~ 400V Output: 3~ 400V 0-500Hz	VoltPro 1.5kW Input: 3~ 400V Output: 3~ 400V 0-500Hz	VoltPro 1.5kW Input: 3~ 400V Output: 3~ 400V 0-500Hz	VoltPro 2.2kW Input: 3~ 400V Output: 3~ 400V 0-500Hz

/ Construction Type of B3

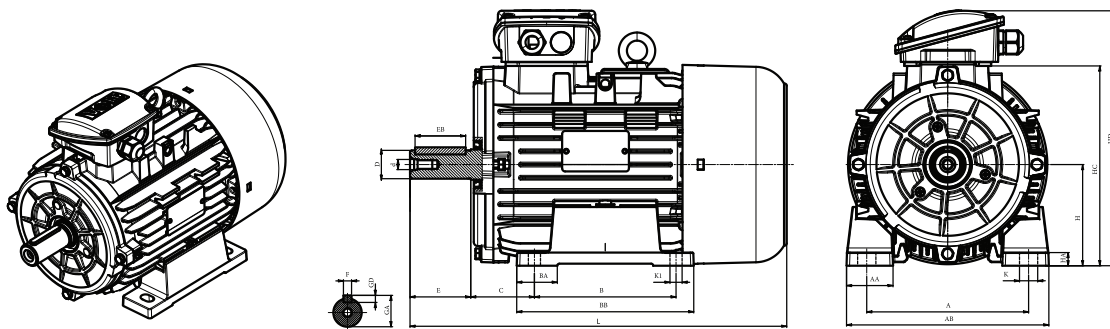

TYPE	A	AA	AB	AC	B	BB	BA	C	D	d	E	EB	F	GD	GA	H	HA	HC	HD	K	K1	L
80 SHORT	125	35	160	158,5	100	125	32	50	19	M6	40	32	6	6	21,5	80	13	159	263	15	10	262,5
80 MID	125	35	160	158,5	100	125	32	50	19	M6	40	32	6	6	21,5	80	13	159	263	15	10	339,5
100 SHORT	160	46	200	197	140	175	40	63	28	M10	60	50	8	7	31	100	13	197,5	252,2	18	12	372,4
100 LONG	160	46	200	197	140	175	40	63	28	M10	60	50	8	7	31	100	13	197,5	252,5	18	12	412

/ Construction Type of B14

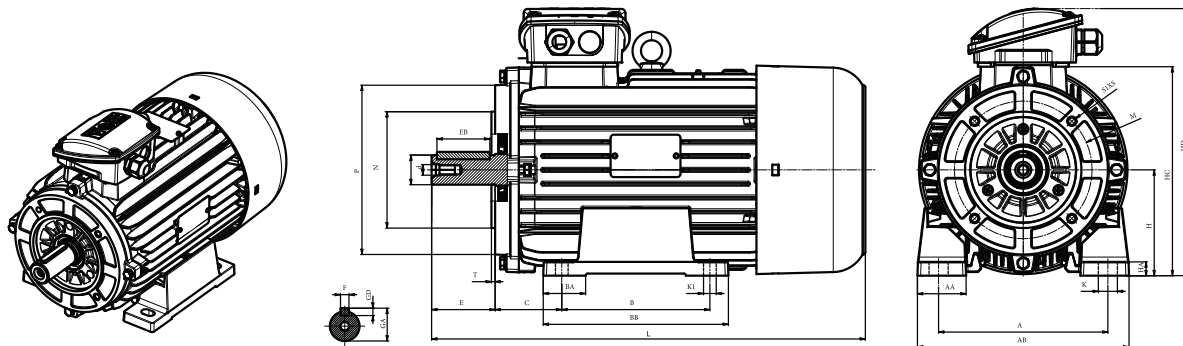

TYPE	A	AA	AB	AC	B	BB	BA	C	D	d	E	EB	F	GD	GA	H	HA	HC	HD	K	K1	L
80 SHORT	125	35	160	158,5	100	125	32	50	19	M5	40	32	6	6	21,5	80	13	159	263	15	10	262,5
80 MID	125	35	160	158,5	100	125	32	50	19	M5	40	32	6	6	21,5	80	13	159	263	15	10	339,5
100 SHORT	160	46	200	197	140	175	40	63	28	M10	60	50	8	7	31	100	13	197,5	252,2	18	12	372,4
100 LONG	160	46	200	197	140	175	40	63	28	M10	60	50	8	7	31	100	13	197,5	252,5	18	12	412

/ Construction Type of B35

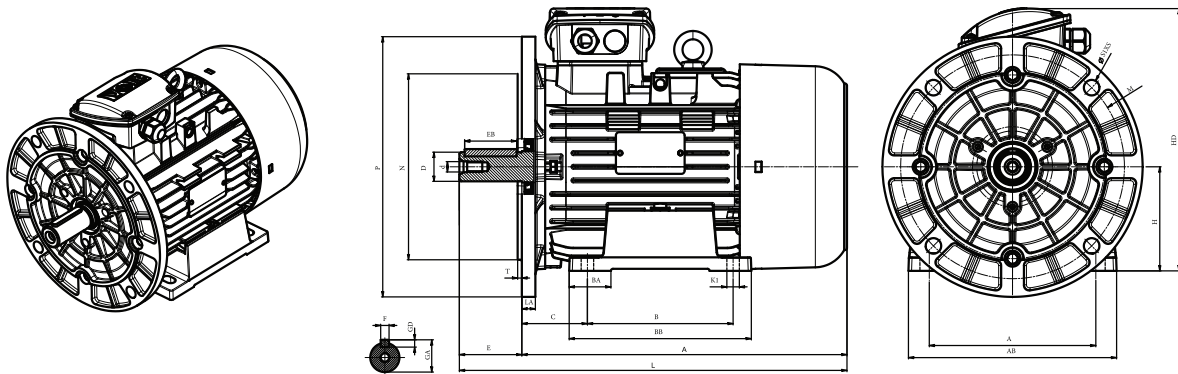

TYPE	A	AA	AB	AC	B	BB	BA	C	D	d	E	EB	F	GD	GA	H	HA	HC	HD	K	K1	L
80 SHORT	125	35	160	158,5	100	125	32	50	19	M5	40	32	6	6	21,5	80	13	159	263	15	10	262,5
80 MID	125	35	160	158,5	100	125	32	50	19	M5	40	32	6	6	21,5	80	13	159	263	15	10	339,5
100 SHORT	160	46	200	197	140	175	40	63	28	M10	60	50	8	7	31	100	13	197,5	252,2	18	12	372,4
100 LONG	160	46	200	197	140	175	40	63	28	M10	60	50	8	7	31	100	13	197,5	252,5	18	12	412

/ Electrical Connection

VoltPro has 3 phase Y connected stator winding. Star point of Y connection is placed inside motor. There is not any wire connection from star point to terminal box. There is 3 wire connection inside terminal box for 3 phase supply output of driver.

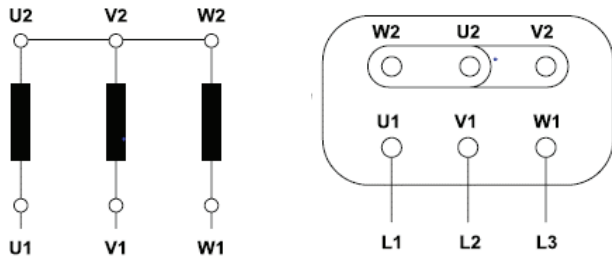

/ Thermal protection

Thermal protection of motor can be provided in two ways. First is to use PTC (Positive Thermal Coefficient Resistance) and second is to define current limit in driver setup. 3 pcs of PTC connected electrically in series is laced inside the stator winding to detect winding temperature. PTC is connected to a relay or driver electronic board. When PTC is connected to driver, driver can measure winding temperature on-line and after a threshold temperature is reached, the motor load is decreased or stopped and driver display overheating signal. PTC placement in winding is optional and on request by customer.

/ Insulation System

Stator winding insulation system is made by using insulation paper inside the slot and plastic support for both side of stator lamination. Plastic material of support is special material for high voltage application and appropriate for EU norm.

Thanks to needle winding technology so this motor has fully electrical insulated winding that means there is not any physical contact between each phase winding, there is no need for insulation between phases. By the way for inverter duty running, it is more reliable than classical distributed winding technology.

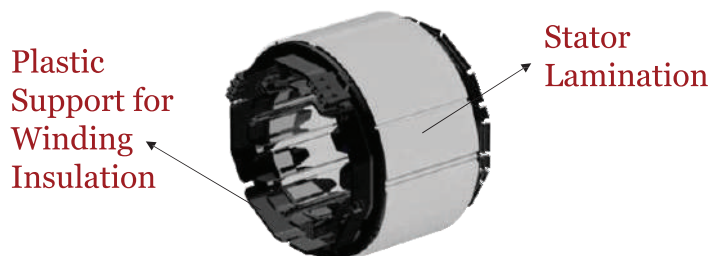

/ VoltPro Advantages of PMSM For The Application

VoltPro PMSM motor is the best choice for the applications need variable speed and power where the motor can be used as a load sensor to detect the torque or power need of load. Especially for pump, fan and compressor applications, the load needs of system change continuously and drive system should be able to sense this change to save energy and to increase efficiency of system. For some application this can be done without using any sensor, in example pressure or flow rate control for a pump or fan systems. Thanks to linear torque vs current characteristic of motor so that torque or power needs of system can be measured by using motor as a sensor while the motor runs. Special control algorithms can be implemented in firmware for this purpose. VoltPro can support you on request.

Application Without Fan

VoltPro motor series have high efficiency level (>IE5) that means low loss so that it can be used without fan for special application where the noise is critical. In this case the motor can be used with decreased rated power without fan cooling system.

Controllability of Motor

VoltPro was designed for sensor less control with FOC drive. It has a saliency, difference between "d" and "q" axis inductance, in its rotor magnetic circuit. By the means of this, it can be driven with different sensorless drive algorithms. Such as, high frequency injection, estimators using monitored stator voltage or currents, flux based position estimators, position estimators based on back-EMF, observed-based estimators (Luenberg observer, sliding mode observer, Kalman filter). PMSM drives without mechanical sensors for motor position or speed have the attraction of lower cost and higher reliability.

Motor inductance change with current and rotor position is important to drive the motor with optimum load angle. Below parameter list should be considered to drive VoltPro PMSM motor in optimum running. Especially during overload running region, saturated inductance value should be considered in sensorless control algorithm. Motors has low electrical time constant and low mechanical time constant due to low rotor inertia by the means of ferrite magnet usage.

1. L_{dd} "d" axis inductance vs i_d and i_q currents $L_{dd} = \partial \Psi_d / \partial i_d = f(i_d, i_q)$
2. Flux linkage of "d" axis vs i_d and i_q currents
3. L_{qq} "q" axis inductance vs i_d and i_q currents $L_{qq} = \partial \Psi_q / \partial i_q = f(i_d, i_q)$
4. Flux linkage of "q" axis vs i_d and i_q currents
5. L_{dq} cross saturation inductance $L_{dq}(i_d, i_q) = \Delta \lambda_{dq} / \Delta i_q = \text{constant}$
6. L_{qd} cross saturation inductance $L_{qd}(i_d, i_q) = \Delta \lambda_{qd} / \Delta i_d = \text{constant}$
7. L_{dd} "d" axis inductance vs i_d , i_q and rotor position
8. L_{qq} "q" axis inductance vs i_d , i_q and rotor position

Inductance and flux parameters for sensorless drive.

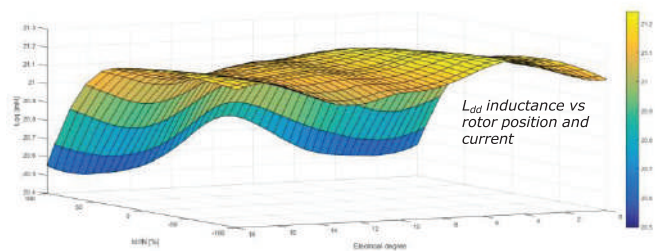

Sample inductance vs current & rotor position

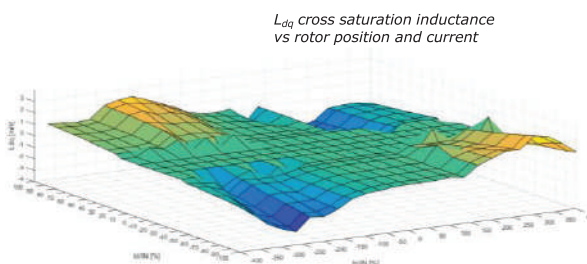

L_{dq} cross saturation inductance vs rotor position and current

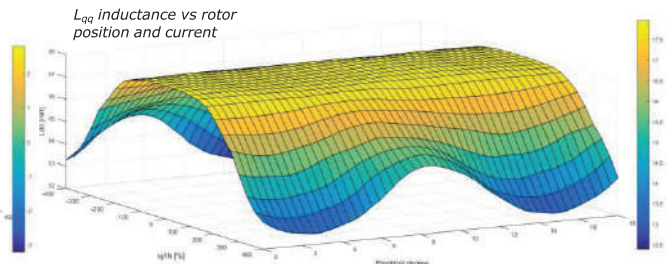

L_{qq} inductance vs rotor position and current

/ Overload Capacity (Saturated Inductances)

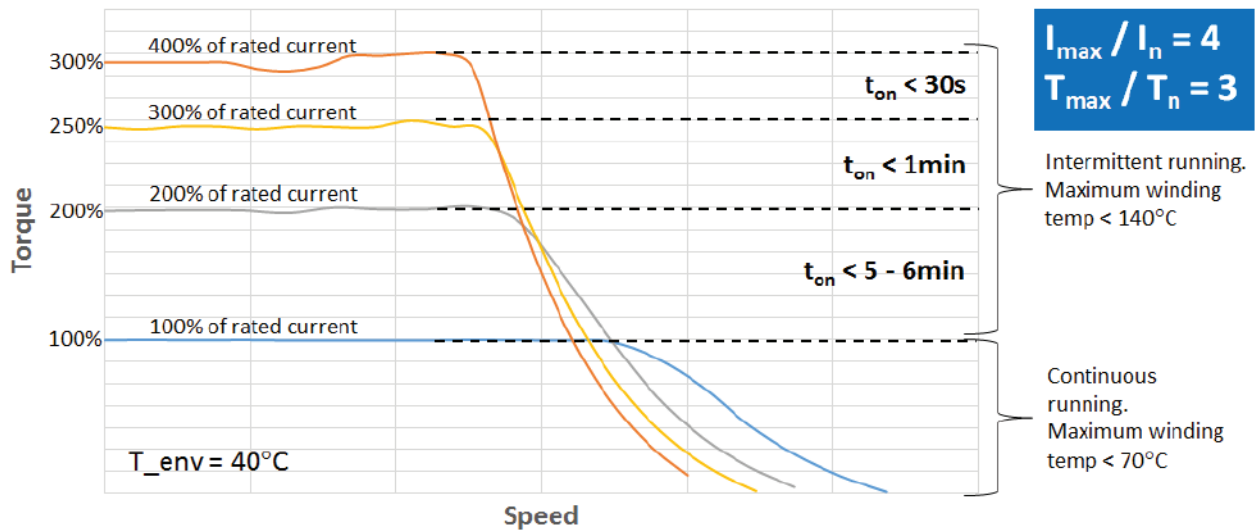

/ Torque vs Speed Graph for 80 Frame Motors

Torque vs speed graph for all types of 80 frame motor range is given below.

Test Condition: 400V 50Hz driver input / gamma angle = 0 (no field weakening)

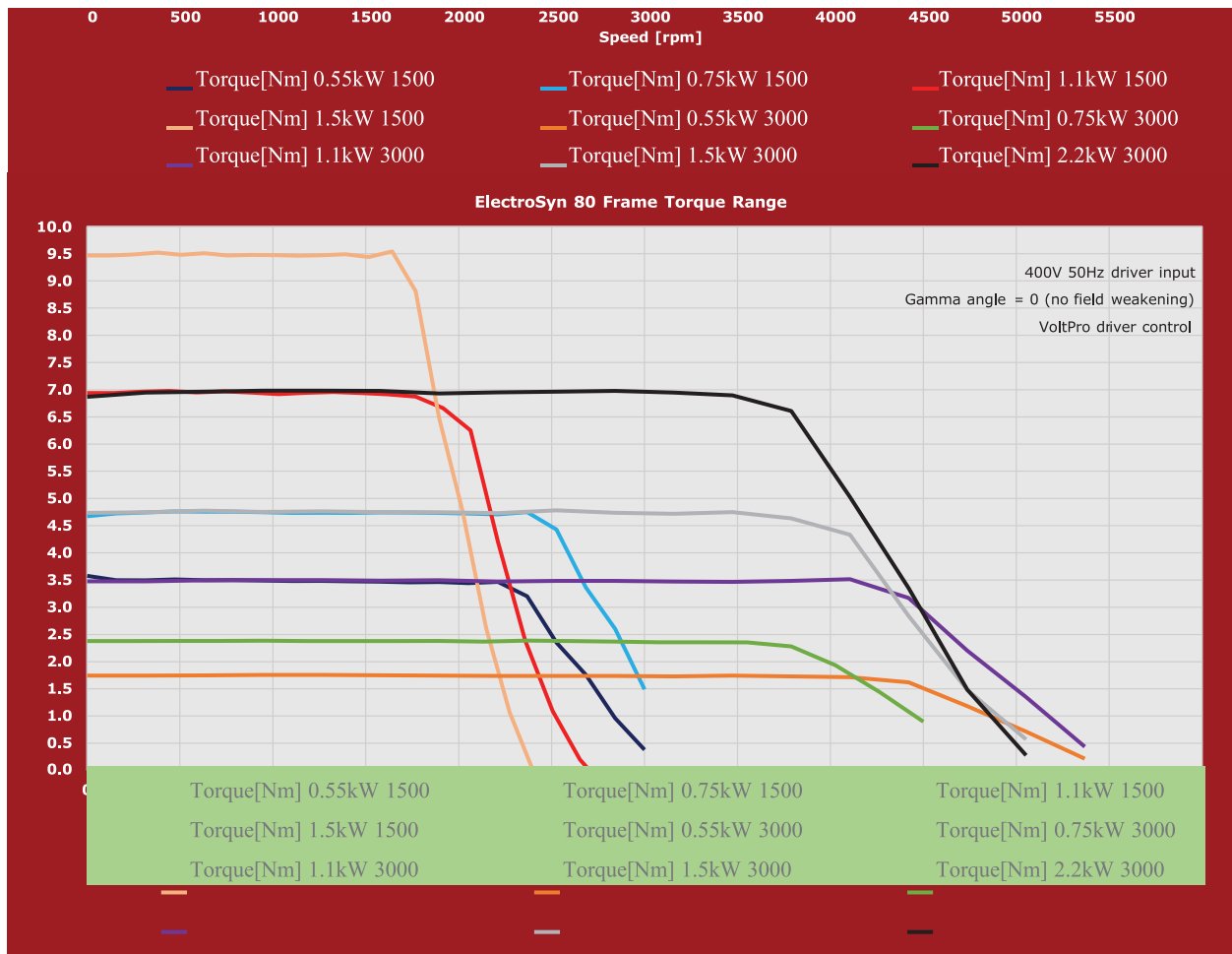

/ Wiring Diagram of VoltPro Driver

VoltPro driver wiring diagram should be done according to below figure. For PID closed loop control with sensor (pressure, flow rate...) external analog inputs can be used. For detail information please examine on manual.

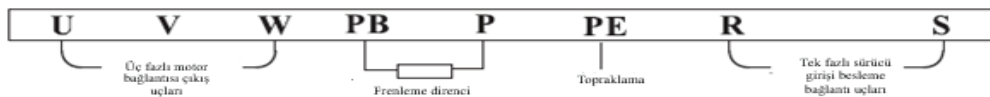
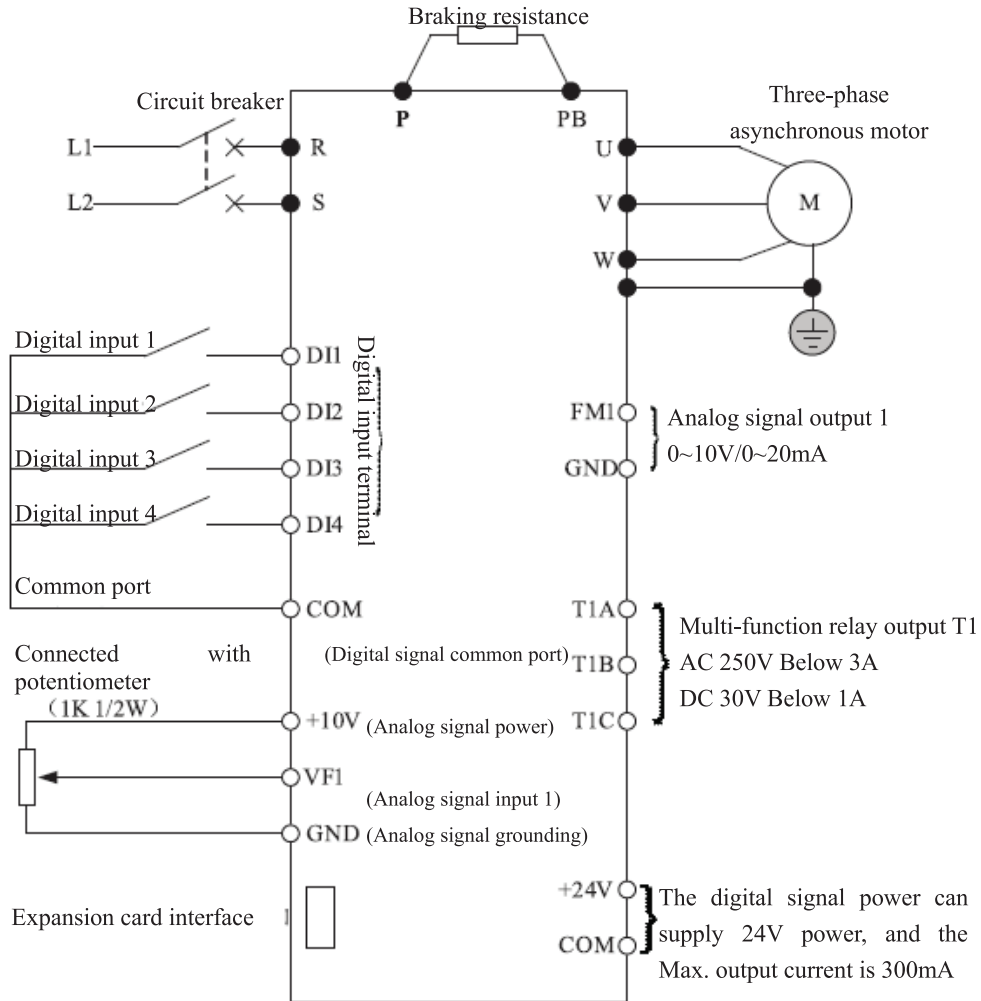

MEET THE WORLD'S EFFICIENT ELECTRIC MOTOR

$\eta > IE5$

Low Cost and High Efficiency in One

NEW TECHNOLOGY
COMPACT SERIES

Voltpro
electric motors
" Upgrade your energy "

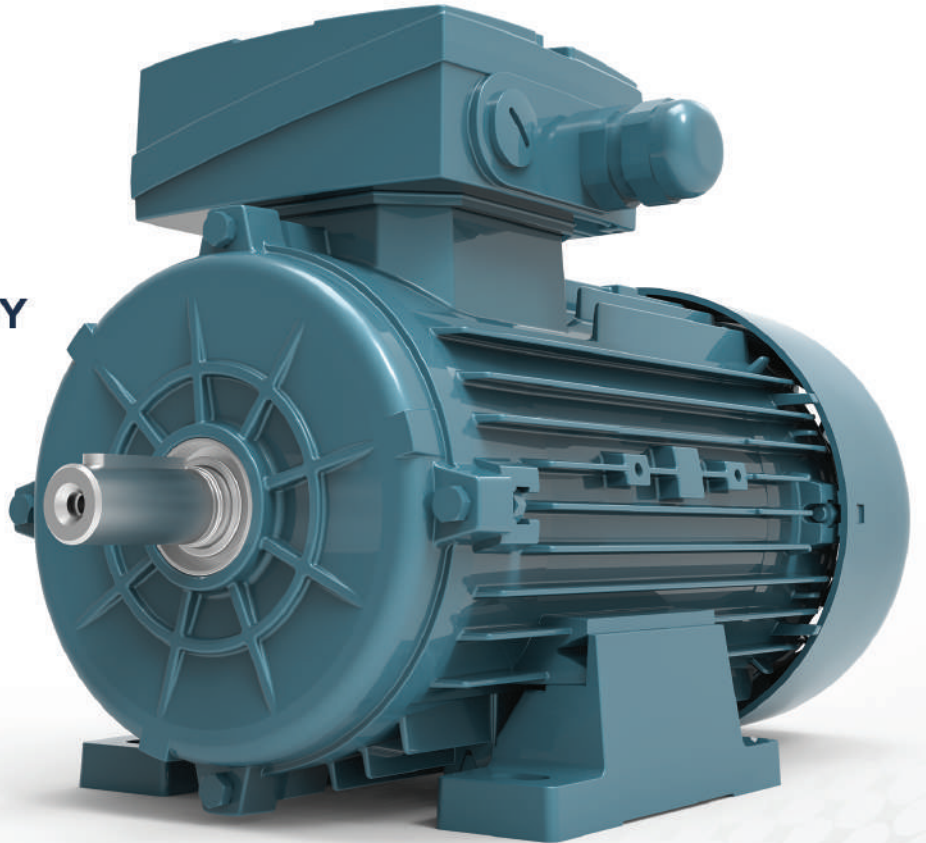

Volt electric
motors

www.voltmotor.com.tr

SAYA
GRUP



Kazım Karabekir Cad. No:84 Kemalpaşa
35735 İzmir / Türkiye / **Tel: +90 (232) 877 10 60 (pbx)**
Faks: +90 (232) 877 10 59 / E-mail: bilgi@voltmotor.com.tr
satis@voltmotor.com.tr